

Use headlocks in freestall barns!

Dairy cows need many routine treatments and check-ups to stay productive and healthy. In conventional barns (tie-stall & stanchion), this intensive management is relatively easy. In freestall barns, with cows “on the loose”, it can become a challenge to find individual cows and treat them. Installing and using headlocks (self-locking headgates) can be a profitable way to solve this problem!

Animal handling. With intensive management, each cow may need individual attention for important check-ups or treatments up to 50 times per lactation cycle. Headlocks make it easy to identify animals and make it possible to carry out the work safely and efficiently. Without headlocks, animals are “on the loose”, and need to be located and identified. The animals then need to be separated from their group and moved to a central pen. After the treatment or checkup is finished, the animals need to be re-sorted and moved back to their original pens. When there are headlocks in the animals’ regular pens, the animals can restrain themselves, they are presented for easy identification and they do not need to be moved away from their pens. Headlocks can save a total of about 133 hrs/yr in a herd of 125 cows and replacements by reducing this kind of routine animal handling (AI breeding not included).

AI Breeding. Heat detection is crucial to efficient AI breeding. Using headlocks makes it easier to use tail chalk or tail paint routines which may improve heat detection and save labor. Efficient and safe AI breeding requires reliable identification and restrained animals. Farmers who hire AI technicians to do custom heat detection and breeding are charged up to 50% more if headlocks are not provided. Some AI technicians do not offer their services in herds without headlocks. Based on the fees charged for custom breeding, using headlocks for cows as well as heifers may save around 159 hrs/yr in a 125 cow herd. Depending on the routines used, headlocks may also improve heat detection and marginally improve the conception rate.

Feed intake and milk production. Some studies have been interpreted to mean that cows eat less feed when using headlocks as compared to post-and-rail feed barriers. However, other research suggests that what may look like decreased feed intake actually is decreased feedout loss, since cows restrained in headlocks are less able to toss and drop feed into the scrape alley. Importantly, these studies comparing neck rails and head locks have found no differences in milk yield, which supports the argument that there is no

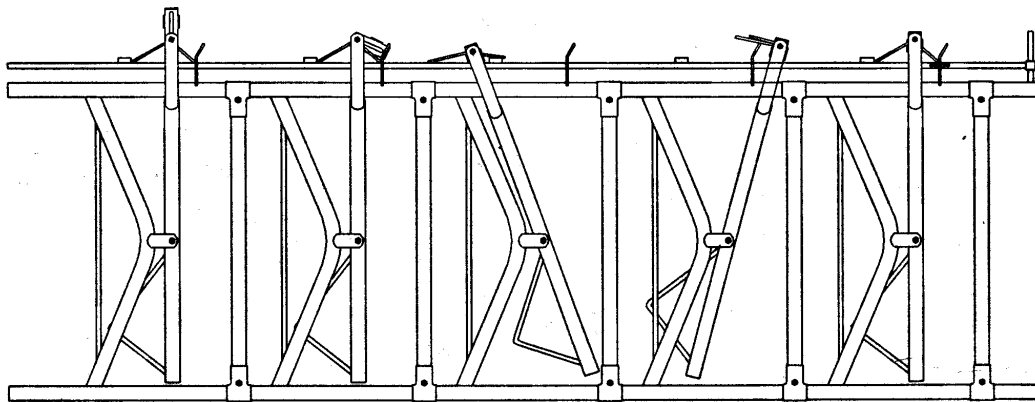

Using Headlocks for cows and older heifers saves animal handling labor and may reduce feed-out loss.

**WORK
EFFICIENCY**



TIP SHEET

Ideas for more efficient dairy farm work.

*Gunnar Josefsson,
Marcia Miquelon
and Larry Chapman*

*University of Wisconsin,
Madison
Healthy Farmers,
Healthy Profits Project*

difference in the amount of feed actually consumed. For lactating cows, headlocks can be expected to save about 2.5% of the amount fed, or 1.25 lb. DM/cow/day. This adds up to feed-savings of about \$4,170/yr in a herd of 125 cows and replacements. Researchers point out that cows need to be accustomed to feeding in headlocks. If not, they are likely to consume less feed and as a result produce less milk. This training is best achieved by also using headlocks in pens for the replacement heifers.

Working conditions. Rounding up and “chasing” cows or heifers splashes manure and is no fun for farm workers. Veterinarians and AI technicians prefer headlocks because they increase work safety and precision.

Profitability. Investing in headlocks for cows and replacement heifers can save both labor and feed costs, making it a profitable investment for a 4-row freestall barn. In a 3-row or 6-row barn, there is not enough space for all cows to eat at once. Installing headlocks only worsens this problem. In addition, up to a third of cows are still on the loose. Therefore, headlocks are not recommended for the entire feedbunk in 3- or 6-row barns.

Where to buy headlocks.

You can buy headlocks from farm equipment suppliers or directly from manufacturers at a cost of about \$55-\$85/cow. Here is an example list of known manufacturers for easy reference. *The list is provided for the reader’s convenience and does not imply an endorsement by the University of Wisconsin:*

- ♦ **Albers Dairy Equipment**
1-800-872-5441
www.albersdairyequipment.com
- ♦ **Agromatic Inc.**
920-922-1970
www.agromatic.net
- ♦ **Berg Equipment Corp**
715-384-2151 or 1-800-494-1738
bergbennett@lycosmail.com
- ♦ **Freudenthal Dairy & Mfg Co.**
715-748-4132
www.freudenthalmfg.com
- ♦ **Nielsen Industries Inc.**
602-269-5727 or 602-272-3852
www.nielsenind.com
- ♦ **Norbco Industries**
608-374-3602
www.norbco.com

This material was developed by the Wisconsin Healthy Farmers, Healthy Profits Project. Our goal is to find and share work efficiency tips that maintain farmers’ health and safety and also increase profits. For more information, call (608)262-7408 or visit our website at [http:// bse.wisc.edu/hfhp/](http://bse.wisc.edu/hfhp/)

Table 1. Summary of cost-effectiveness when investing in headlocks¹⁾

	Pay-back period (years)	Annual net profit (\$/yr)
Labor savings and reduced feed costs pay off the investment	1.4	5,377 (\$43/cow/yr)
Only reduced feed costs pay off the investment	2.2	2,747 (\$22/cow/yr)

1) Example for herd of 125 cows with replacements (35% annual replacement rate)

Material is not copyrighted. Feel free to reproduce; please mention source: University of Wisconsin Healthy Farmers, Healthy Profits Project, May 2003; First Edition.

Authors: Gunnar Josefsson, Marcia Miquelon and Larry Chapman, Department of Biological Systems Engineering, College of Agricultural and Life Sciences, 460 Henry Mall, University of Wisconsin, Madison, WI 53706.

Research for this publication: was funded by the U.S. Centers for Disease Control and Prevention’s National Institute for Occupational Safety and Health (NIOSH).

Work Efficiency Tip Sheet: Use headlocks in freestall barns!

